

# Remote Condensing Unit



<b>Dimensions:</b>	17.2 in (W) 43 cm x 40.6 in (D) 101.6 cm x 33.1 in (H) 84 cm
<b>Weight:</b>	210 lbs (95kg)
<b>Shipping Size:</b>	31 in (W) x 36 in (L) x 23 in (H) 79 cm (W) x 91 cm (L) x 58 cm (H)
<b>Shipping Volume:</b>	15.5 cu ft (1/2 cu m)
<b>Shipping Weight:</b>	251 lbs (98 kg)
<b>Voltage:</b>	208 - 230
<b>Hertz:</b>	60 hz - Optional 50 hz
<b>Phase:</b>	1 - Optional 3
<b>Cooling:</b>	Air Cooled - Optional Water
<b>Air Clearance:</b>	Intake 16 in (40.64 cm) Exhaust: 60 in (152 cm)
<b>Amperage Draw:</b>	24 amps (12 at 3 ph)
<b>Circuit Breaker:</b>	30 amps minimum
<b>Compressor:</b>	3 hp
<b>Refrigerant:</b>	R448A



Due to continuous research specifications are subject to change without notice.

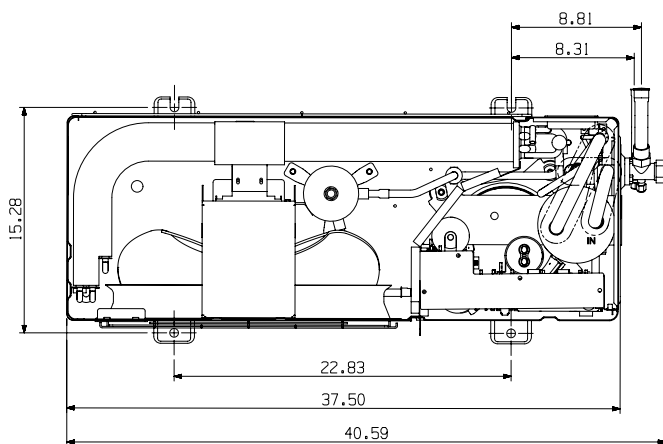

VIEW WITHOUT COVER TOP ⑥

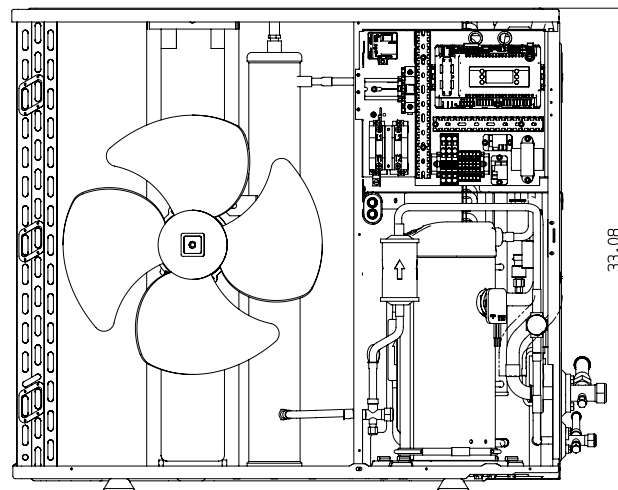

VIEW WITHOUT COVER FRONT LEFT, GUARD FAN & DOOR ASSM ⑦

# Specifications

## Remote Condensing Unit

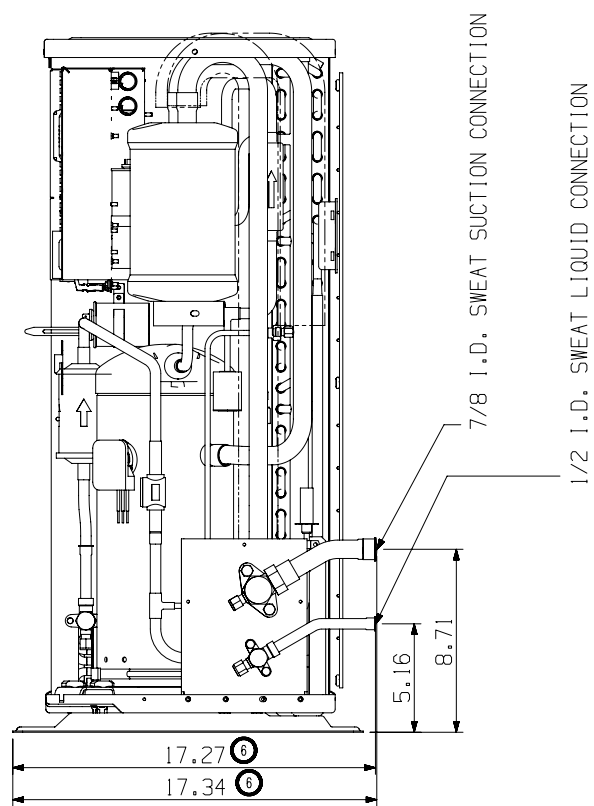

VIEW WITHOUT COVER RIGHT ⑥

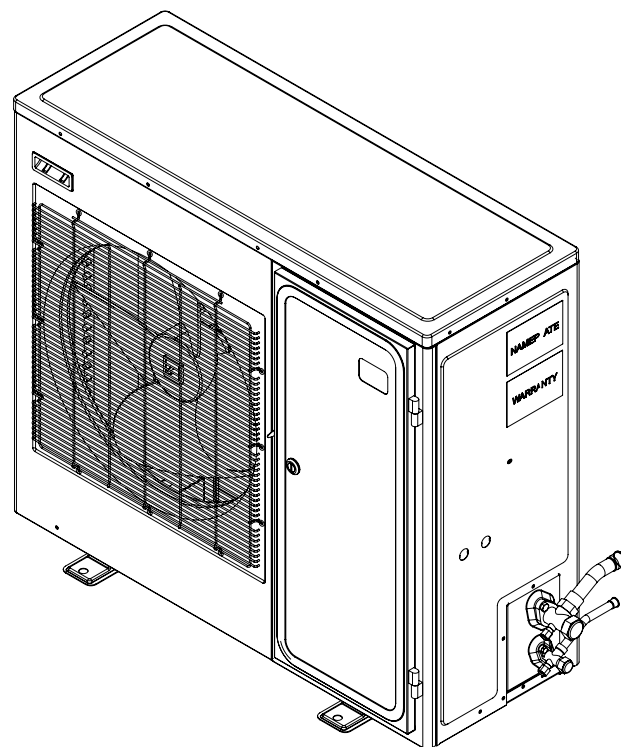

SCALE 3:16